

★ 780nm 10mW 60°C Reliable Operation

● Features

1. High temperature operation (60°C)
2. High FFP deviation angle

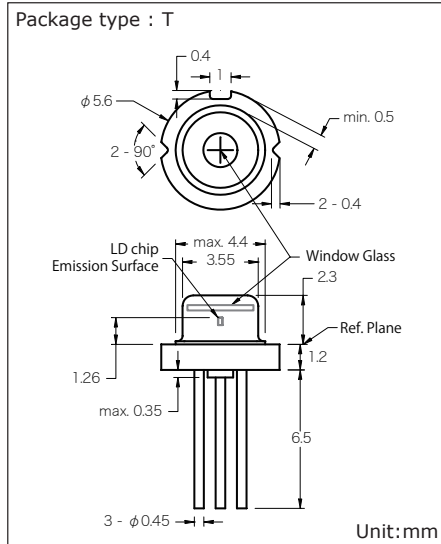

Fig.1:Outside view

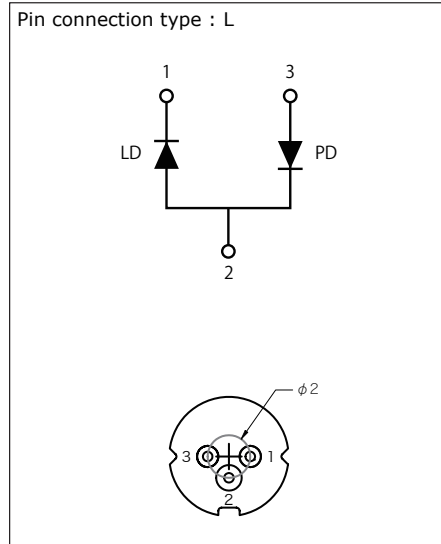

Fig.2:Pin connection

● Absolute maximum ratings

Parameter	Symbol	Condition	Rating	Unit
Light output power	P_o	CW	12	mW
Reverse voltage (LD)	V_{RL}	-	2	V
Reverse voltage (PD)	V_{RD}	-	30	V
Forward current (PD)	I_{FD}	-	10	mA
Case temperature	T_c	-	-10~+60	°C
Storage temperature	T_s	-	-40~+85	°C

● Electrical and optical characteristics ($T_c=25^\circ\text{C}$)

Parameter	Symbol	Min.	Typ.	Max.	Unit	Conditions
Peak wavelength	λ	770	780	790	nm	$P_o=10\text{mW}$
Threshold current	I_{th}	-	15	25	mA	
Operating current	I_{op}	-	30	40	mA	$P_o=10\text{mW}$
Operating voltage	V_{op}	-	1.9	2.2	V	$P_o=10\text{mW}$
Differential efficiency	η	0.4	0.6	0.8	mW/mA	$P_o=7\text{-}10\text{mW}$
Monitor current	I_m	0.2	0.6	1.2	mA	$P_o=10\text{mW}, V_{RD}=5\text{V}$
Parallel divergence angle	$\theta_{//}$	7	11	15	deg	$P_o=10\text{mW}$
Perpendicular divergence angle	θ_{\perp}	24	28	32	deg	
Parallel FFP deviation angle	$\Delta\theta_{//}$	-2	0	+2	deg	
Perpendicular FFP deviation angle	$\Delta\theta_{\perp}$	-3	0	+3	deg	
Emission point accuracy	$\Delta x\Delta y\Delta z$	-80	0	+80	μm	

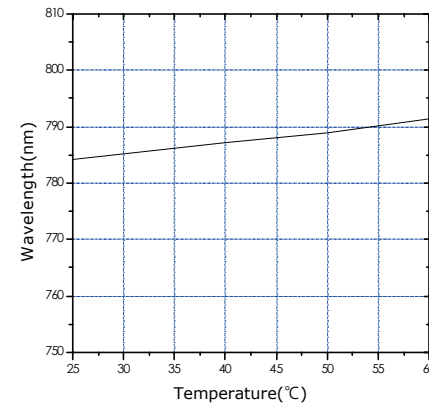
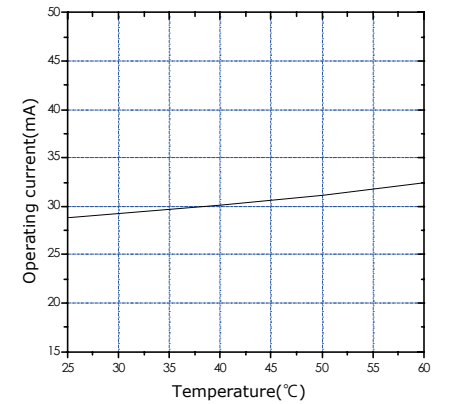
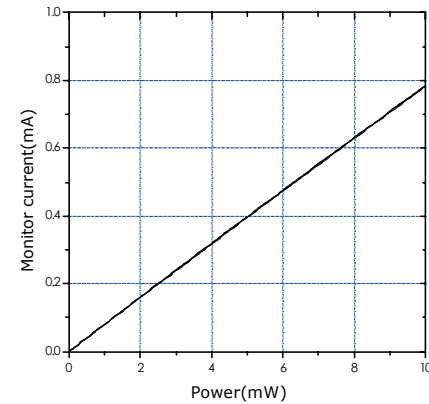
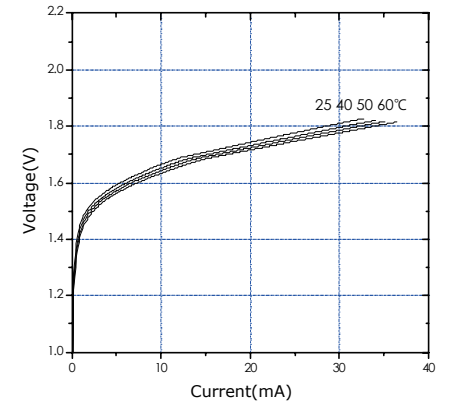
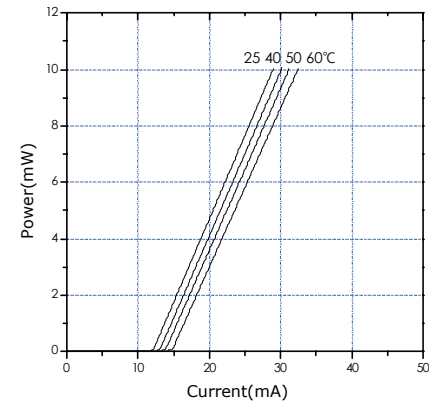

● Precautions

- * Do not operate the device above maximum ratings. Doing so may cause unexpected and permanent damage to the device.
- * Take precautions to avoid electrostatic discharge and/or momentary power spikes. A change in the characteristics of the laser or premature failure may result.
- * Proper heat sinking of the device assures stability and lifetime. Always ensure that maximum operating temperatures are not exceeded.
- * Observing visible or invisible laser beams with the human eye directly, or indirectly, can cause permanent damage. Use a camera to observe the laser.
- * No laser device should be used in any application or situation where life or property is at risk in event of device failure.
- * Specifications are subject to change without notice. Ensure that you have the latest specification by contacting us prior to purchase or use of the product.