

## ★ 660nm 50mW 60°C Reliable Operation

### ● Features

1. High temperature operation (60°C)
2. High Visibility

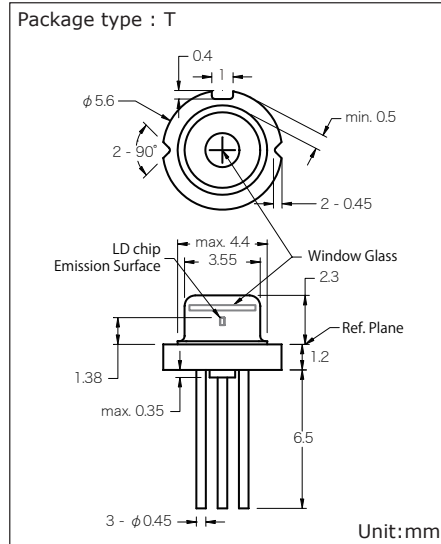

Fig.1:Outside view

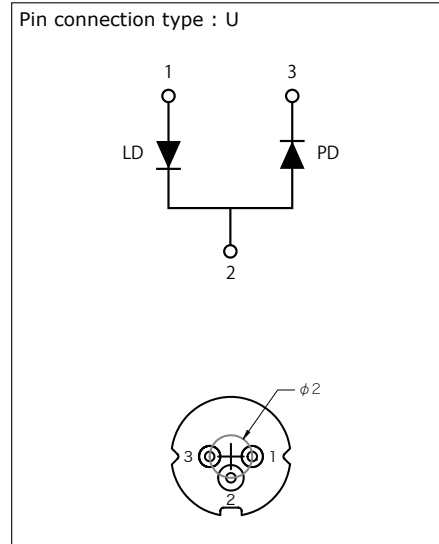

Fig.2:Pin connection

### ● Absolute maximum ratings

Parameter	Symbol	Condition	Rating	Unit
Light output power	$P_o$	CW	52	mW
Reverse voltage (LD)	$V_{RL}$	-	2	V
Reverse voltage (PD)	$V_{RD}$	-	30	V
Forward current (PD)	$I_{FD}$	-	10	mA
Case temperature	$T_c$	-	-10~+60	°C
Storage temperature	$T_s$	-	-40~+85	°C

### ● Electrical and optical characteristics ( $T_c=25^\circ\text{C}$ )

Parameter	Symbol	Min.	Typ.	Max.	Unit	Conditions
Peak wavelength	$\lambda$	653	660	667	nm	$P_o=50\text{mW}$ , CW
Threshold current	$I_{th}$	-	45	60	mA	
Operating current	$I_{op}$	-	90	120	mA	
Operating voltage	$V_{op}$	2.0	2.5	3.0	V	
Differential efficiency	$\eta$	0.7	1.0	1.4	mW/mA	$P_o=45\text{--}50\text{mW}$
Monitor current	$I_m$	0.05	0.2	0.5	mA	$P_o=50\text{mW}$ , $V_{RD}=5\text{V}$
Parallel divergence angle	$\theta_{//}$	6	9	13	deg	$P_o=50\text{mW}$
Perpendicular divergence angle	$\theta_{\perp}$	13	17	22	deg	
Parallel FFP deviation angle	$\Delta\theta_{//}$	-3	0	+3	deg	
Perpendicular FFP deviation angle	$\Delta\theta_{\perp}$	-3	0	+3	deg	
Emission point accuracy	$\Delta x\Delta y\Delta z$	-80	0	+80	$\mu\text{m}$	

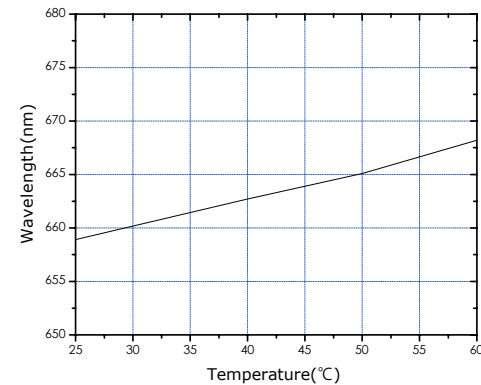
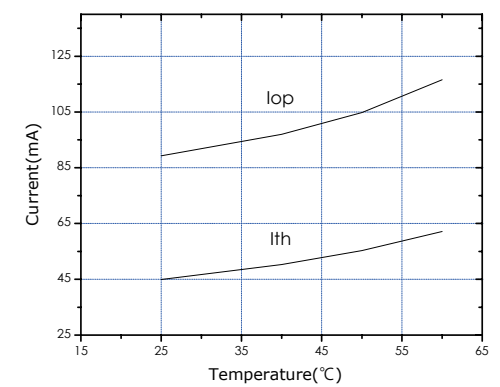
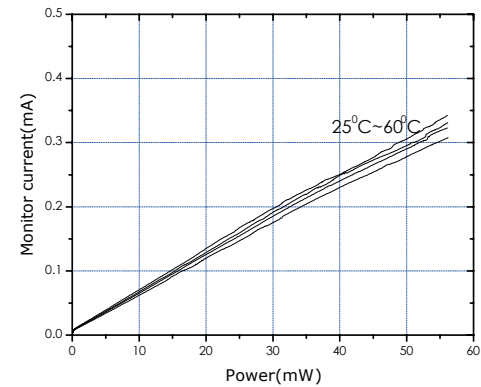
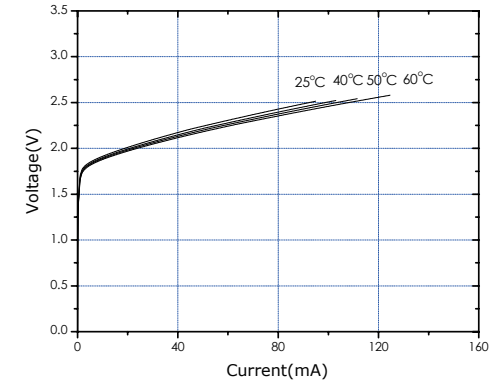
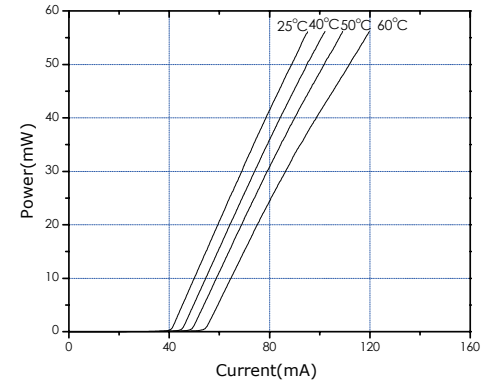

### ● Precautions

- \* Do not operate the device above maximum ratings. Doing so may cause unexpected and permanent damage to the device.
- \* Take precautions to avoid electrostatic discharge and/or momentary power spikes. A change in the characteristics of the laser or premature failure may result.
- \* Proper heat sinking of the device assures stability and lifetime. Always ensure that maximum operating temperatures are not exceeded.
- \* Observing visible or invisible laser beams with the human eye directly, or indirectly, can cause permanent damage. Use a camera to observe the laser.
- \* No laser device should be used in any application or situation where life or property is at risk in event of device failure.
- \* Specifications are subject to change without notice. Ensure that you have the latest specification by contacting us prior to purchase or use of the product.